

Above Grade Wall U-value

Material

Material	λ [W/(m·K)]	ε	μ [-]
Blown Cellulose	0.041	0.900	1.000
Fibreglass Batt, generic	0.050	0.900	1.000
Gypsum plasterboard	0.250	0.900	7.000
Plywood 500 kg/m ³	0.130	0.900	135.000
SONOclimat eco4	0.053	0.900	1.000
Softwood 500, typical construction timber	0.130	0.900	

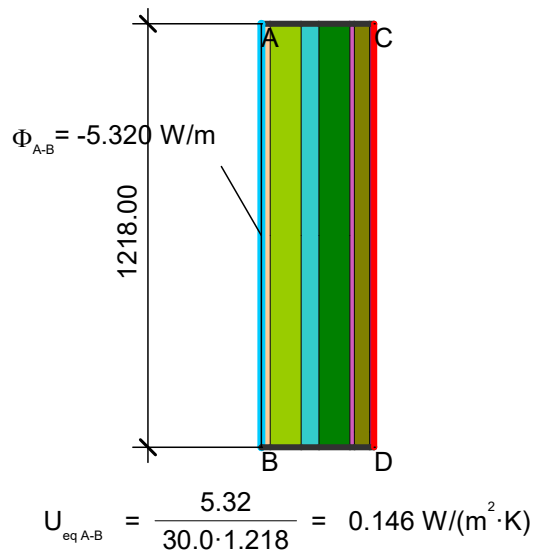
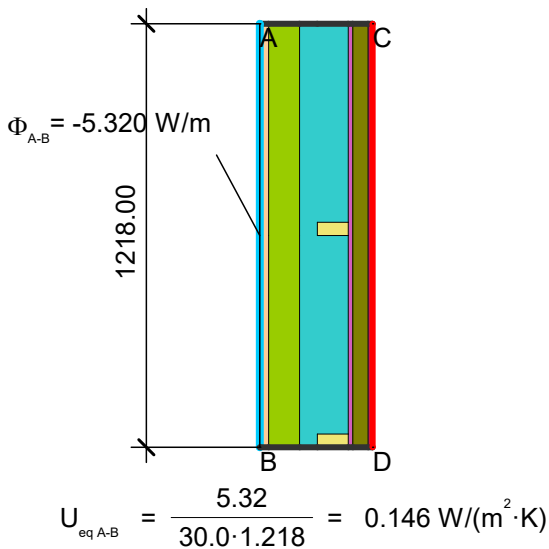
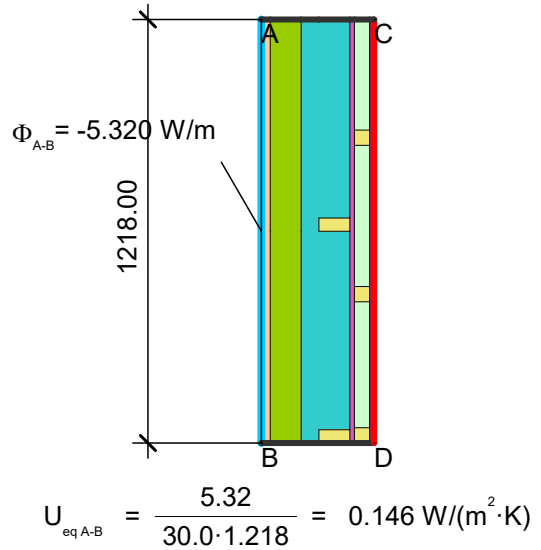
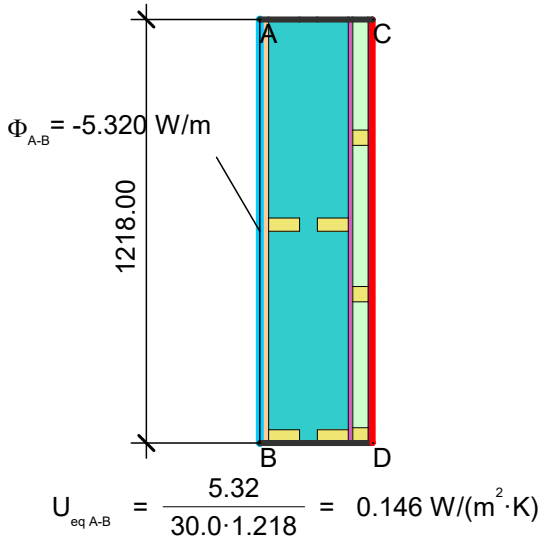

Boundary Condition	q [W/m ²]	θ [°C]	R [(m ² ·K)/W]	ε	ϕ [%]
Exterior, ventilated		-10.000	0.130		
Interior, normal, horizontal		20.000	0.130		
Symmetry/Model section	0.000				

Material	λ [W/(m·K)]	ε	μ [-]
BOSS Wall Eq. Cond. 1	0.045	0.900	1.000
BOSS Wall Eq. Cond. 2	0.057	0.900	1.000
BOSS Wall Eq. Cond. 3	0.045	0.900	1.000
Blown Cellulose	0.041	0.900	1.000
Gypsum plasterboard	0.250	0.900	7.000
Plywood 500 kg/m ³	0.130	0.900	135.000
SONOclimat eco4	0.053	0.900	1.000

Basement Wall U-value

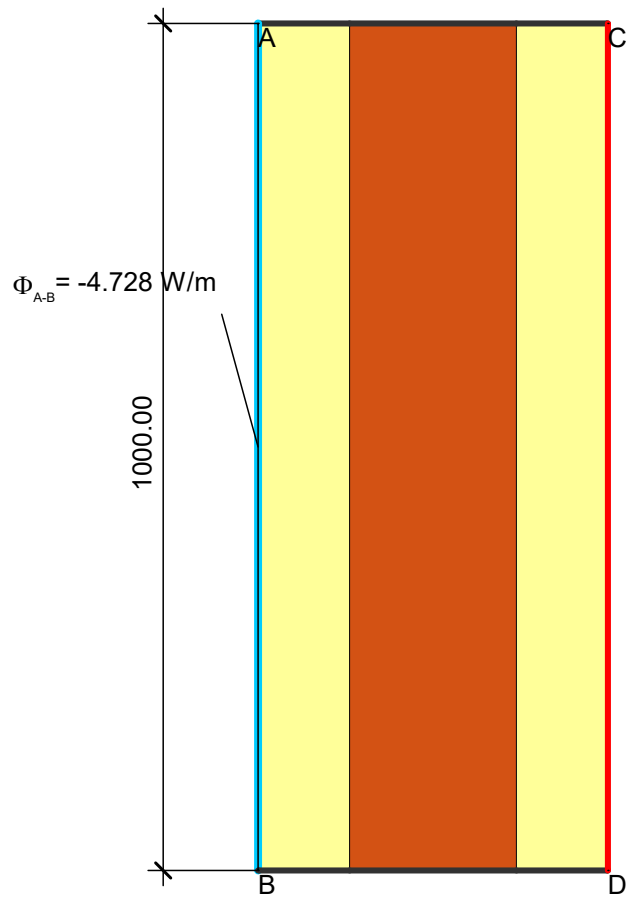

$$U_{eq \text{ A-B}} = \frac{4.728}{30.0 \cdot 1.0} = 0.158 \text{ W}/(\text{m}^2 \cdot \text{K})$$

Material	λ [W/(m·K)]	ϵ	μ [-]
Concrete, reinforced (with 1% of steel)	2.300	0.900	105.000
Type 3 EPS	0.036	0.900	1.000

Boundary Condition	q [W/m ²]	θ [°C]	R [(m ² ·K)/W]	ϵ	ϕ [%]
Exterior, ventilated	-10.000			0.130	
Interior, normal, horizontal		20.000		0.130	
Symmetry/Model section	0.000				

Roof U-value

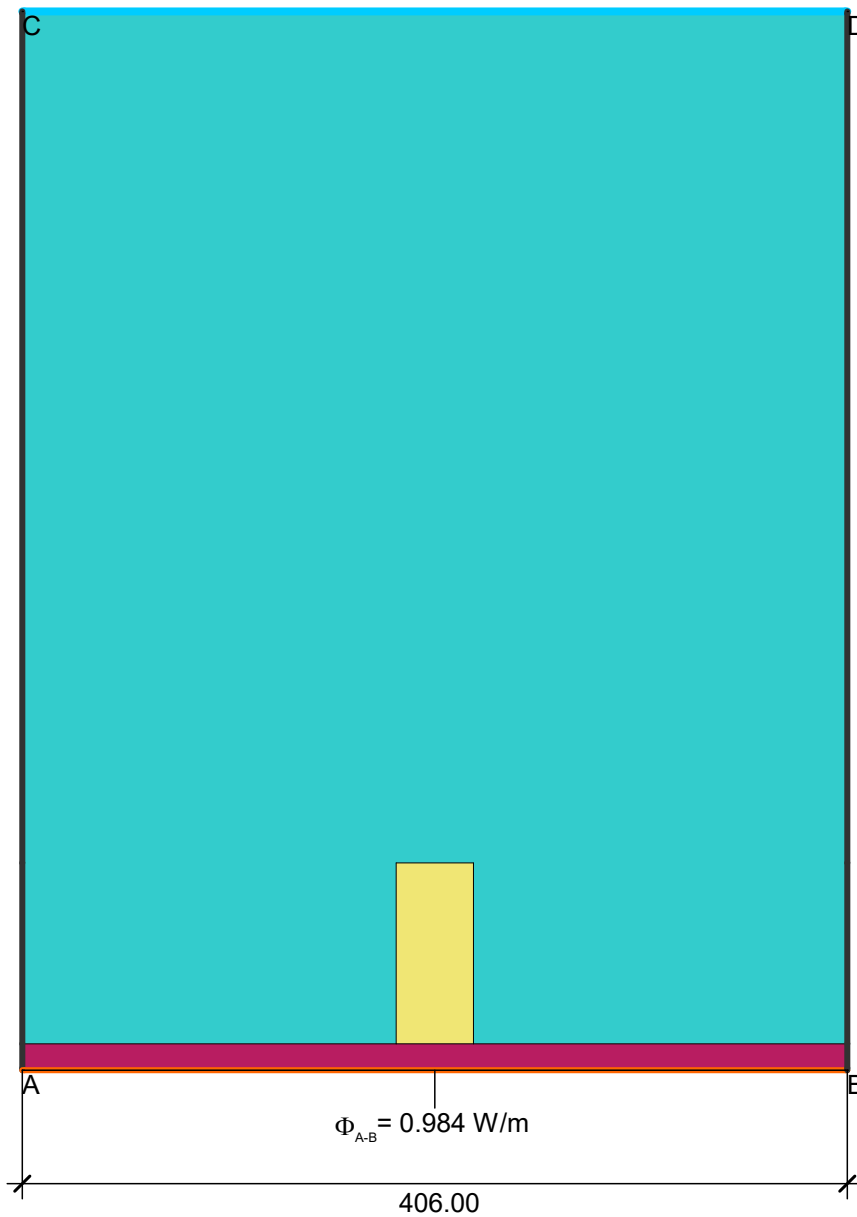

$$U_{eq\ A-B} = \frac{0.984}{30.0 \cdot 0.406} = 0.0808\ W/(m^2 \cdot K)$$

Material	λ [W/(m·K)]	ϵ	μ [-]
Blown Cellulose	0.041	0.900	1.000
Gypsum plasterboard	0.250	0.900	7.000
Softwood 500, typical construction timber	0.130	0.900	

Boundary Condition	q [W/m ²]	θ [°C]	R [(m ² ·K)/W]	ϵ	ϕ [%]
Exterior, ventilated		-10.000		0.130	
Interior, heat flux, upwards		20.000		0.100	
Symmetry/Model section	0.000				

Basement Slab U-value/Heat Flow

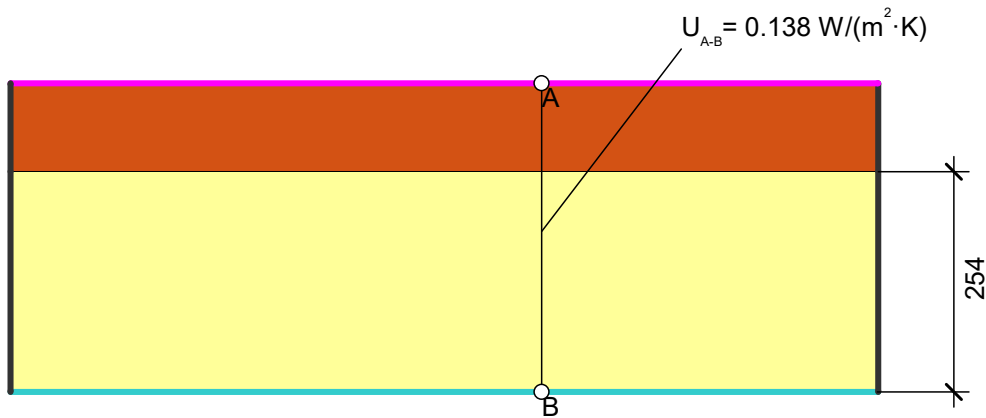

Material	$\lambda[\text{W}/(\text{m} \cdot \text{K})]$	ε	$\mu[-]$
Concrete, reinforced (with 1% of steel)	2.300	0.900	105.000
Type 3 EPS	0.036	0.900	1.000

Boundary Condition	$q[\text{W}/\text{m}^2]$	$\theta[^\circ\text{C}]$	$R[(\text{m}^2 \cdot \text{K})/\text{W}]$	ε	$\phi[\%]$
Exterior, No Rsi		-10.000			
Interior, heat flux, downwards		20.000		0.170	
Symmetry/Model section	0.000				

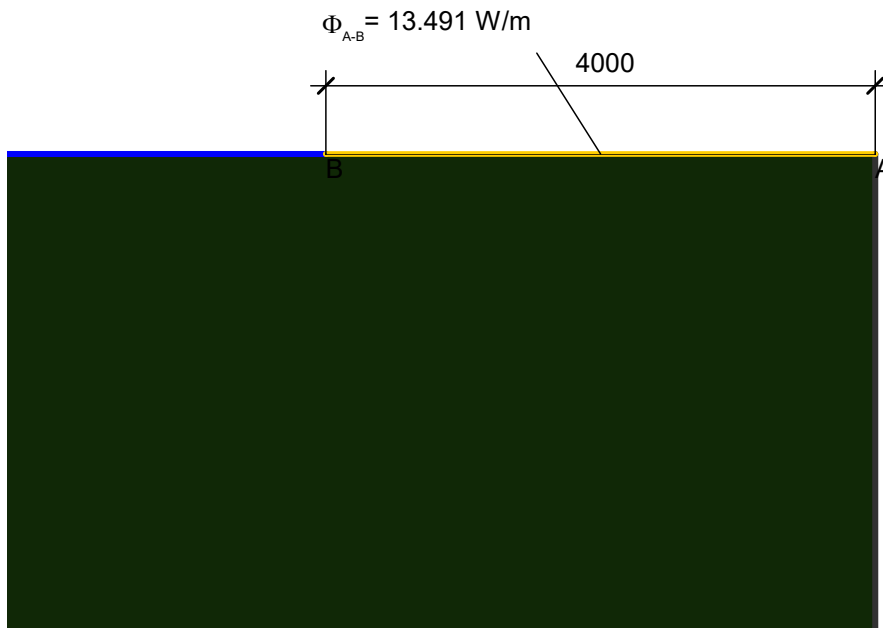

Material	$\lambda[\text{W}/(\text{m} \cdot \text{K})]$	ε	$\mu[-]$
Sand and gravel	2.000	0.900	50.000

Boundary Condition	$q[\text{W}/\text{m}^2]$	$\theta[^\circ\text{C}]$	$R[(\text{m}^2 \cdot \text{K})/\text{W}]$	ε	$\phi[\%]$
BOSS System Basement Slab BC		20.000		7.246	
Exterior, normal		-10.000		0.040	
Symmetry/Model section	0.000				

Slab on Grade U-value/Heat Flow

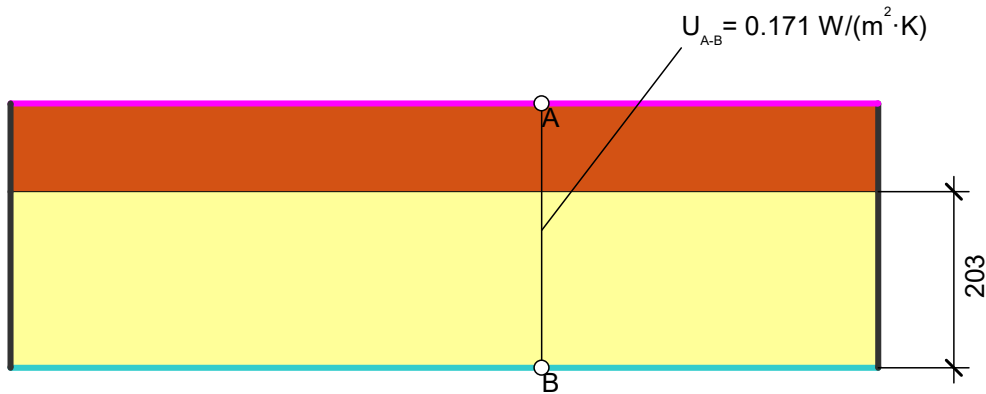

Material	λ [W/(m·K)]	ϵ	μ [-]
Concrete, reinforced (with 1% of steel)	2.300	0.900	105.000
Type 3 EPS	0.036	0.900	1.000

Boundary Condition	q [W/m ²]	θ [°C]	R [(m ² ·K)/W]	ϵ	ϕ [%]
Exterior, No Rsi		-10.000			
Interior, heat flux, downwards		20.000		0.170	
Symmetry/Model section	0.000				

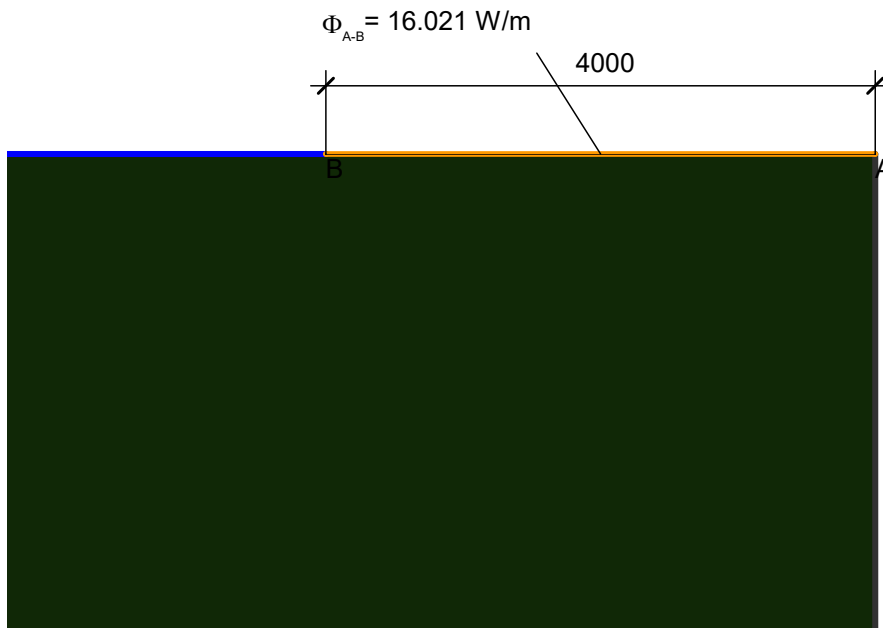

Material	λ [W/(m·K)]	ϵ	μ [-]
Sand and gravel	2.000	0.900	50.000

Boundary Condition	q [W/m ²]	θ [°C]	R [(m ² ·K)/W]	ϵ	ϕ [%]
BOSS System Slab on Grade BC		20.000		5.848	
Exterior, normal		-10.000		0.040	
Symmetry/Model section	0.000				

Window Heat Flow

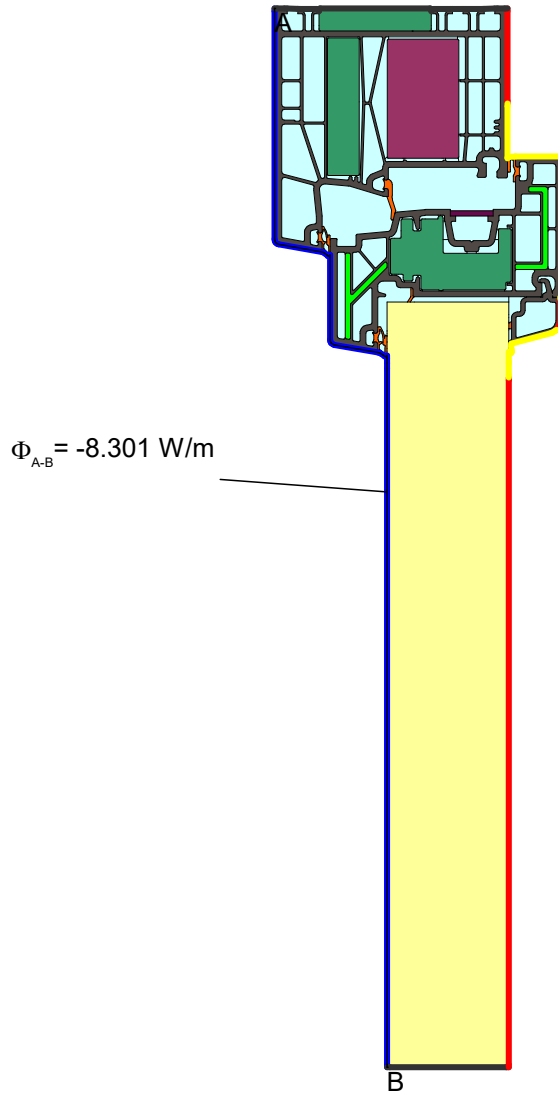

Material	λ [W/(m·K)]	ϵ	μ [-]
Bachl EPS F-040	0.040	0.900	60.000
PVC (polyvinylchloride), rigid	0.170	0.900	
PVC, flexible (PVC-P) 40% softener	0.140	0.900	
Panel	0.035	0.900	
Steel	50.000	0.900	
Steel	50.000	0.300	
Ultradur	0.500	0.900	
illbruck - Pactan P 4031	0.031	0.900	
Unventilated air cavity *			1.000

* EN ISO 10077-2:2017, 6.4.3/anisotrop

Boundary Condition	q [W/m ²]	θ [°C]	R [(m ² ·K)/W]	ϵ	ϕ [%]
Exterior, normal	-10.000		0.040		
Interior, frame, normal	20.000		0.130		
Interior, frame, reduced	20.000		0.200		
Symmetry/Model section	0.000				
Epsilon 0.9				0.900	
ϵ 0.3 (galvanized surface)					0.300

Wall to Intermediate Floor Psi-value

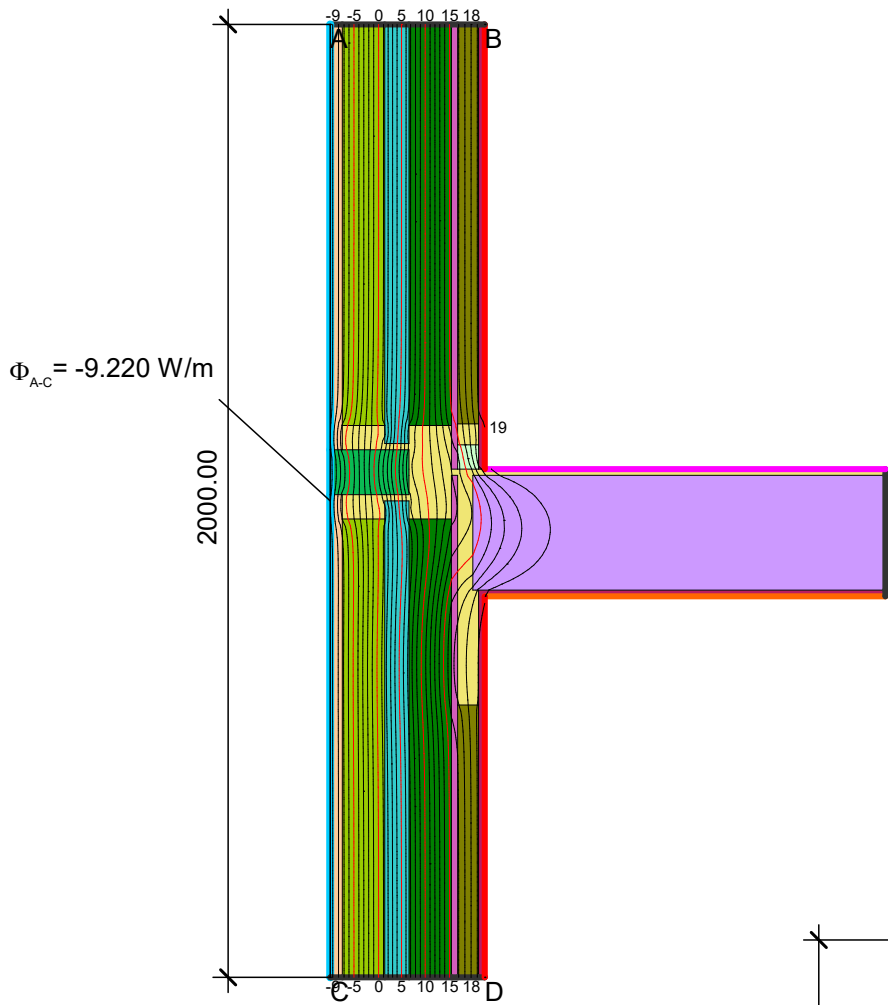

$$\Psi_{A-C,*} = \frac{9.22}{30.0} - 0.146 \cdot 2.0 = 0.016 \text{ W/(m}\cdot\text{K)}$$

Material	λ [W/(m·K)]	ϵ	μ [-]
BOSS Wall Eq. Cond. 1	0.045	0.900	1.000
BOSS Wall Eq. Cond. 2	0.057	0.900	1.000
BOSS Wall Eq. Cond. 3	0.045	0.900	1.000
Blown Cellulose	0.041	0.900	1.000
Blown Cellulose, Low Density	0.054	0.900	1.000
Fibreglass Batt, generic	0.050	0.900	1.000
Gypsum plasterboard	0.250	0.900	7.000
Plywood 500 kg/m ³	0.130	0.900	135.000
ROCKWOOL Brandriegelplatte Coverrock BR	0.036	0.900	1.000
SONOclimat eco4	0.053	0.900	1.000
Softwood 500, typical construction timber	0.130	0.900	

Boundary Condition	q [W/m ²]	θ [°C]	R [(m ² ·K)/W]	ϵ	ϕ [%]
Exterior, ventilated		-10.000	0.130		
Interior, heat flux, downwards		20.000	0.170		
Interior, heat flux, upwards		20.000	0.100		
Interior, normal, horizontal		20.000	0.130		
Symmetry/Model section	0.000				

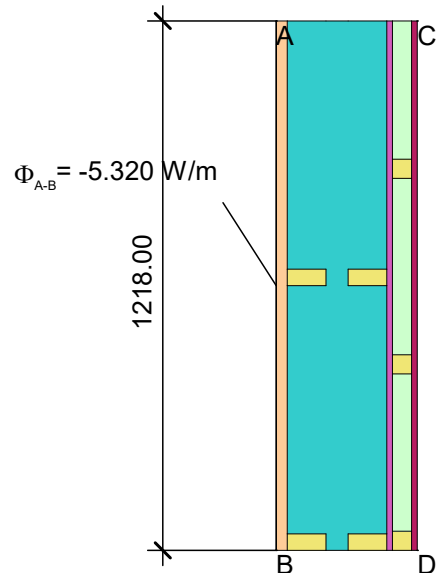

$$U_{eq\ A-B} = \frac{5.32}{30.0 \cdot 1.218} = 0.146 \text{ W/(m}^2\cdot\text{K)}$$

Wall to Roof Psi-value

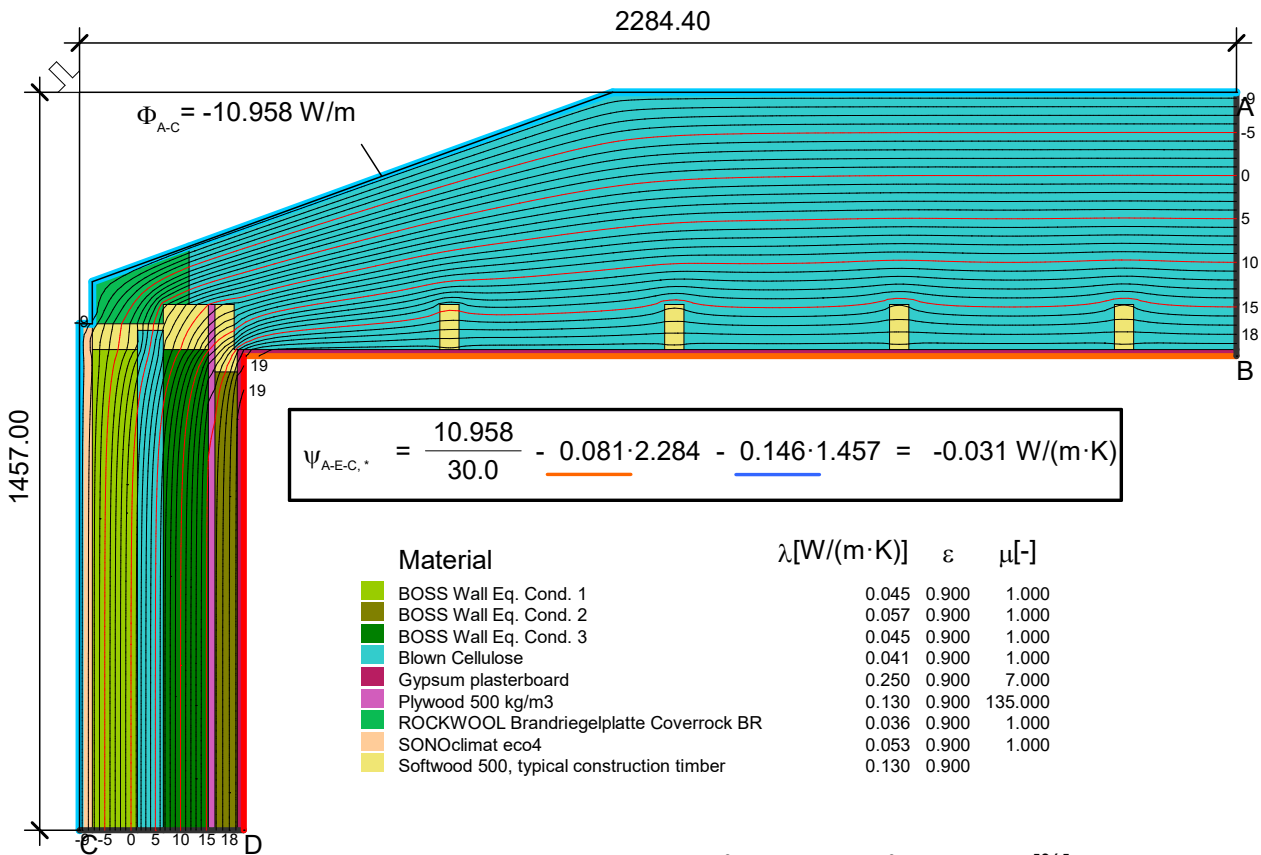

$$\Psi_{A-E-C,*} = \frac{10.958}{30.0} - 0.081 \cdot 2.284 - 0.146 \cdot 1.457 = -0.031 \text{ W}/(\text{m} \cdot \text{K})$$

Material	λ [W/(m·K)]	ϵ	μ [-]
BOSS Wall Eq. Cond. 1	0.045	0.900	1.000
BOSS Wall Eq. Cond. 2	0.057	0.900	1.000
BOSS Wall Eq. Cond. 3	0.045	0.900	1.000
Blown Cellulose	0.041	0.900	1.000
Gypsum plasterboard	0.250	0.900	7.000
Plywood 500 kg/m ³	0.130	0.900	135.000
ROCKWOOL Brandriegelplatte Coverrock BR	0.036	0.900	1.000
SONOclimat eco4	0.053	0.900	1.000
Softwood 500, typical construction timber	0.130	0.900	

Boundary Condition	q [W/m ²]	θ [°C]	R [(m ² ·K)/W]	ϵ	ϕ [%]
Exterior, ventilated	-10.000		0.130		
Interior, heat flux, upwards	20.000		0.100		
Interior, normal, horizontal	20.000		0.130		
Symmetry/Model section	0.000				

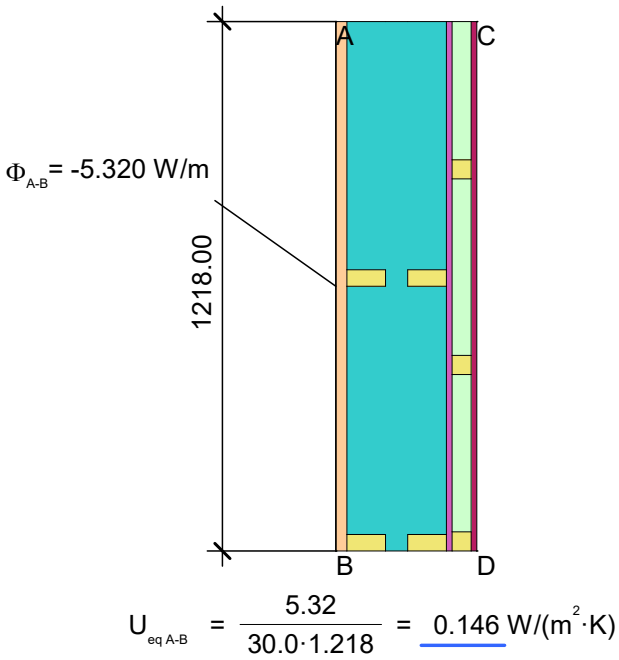

$$U_{\text{eq A-B}} = \frac{5.32}{30.0 \cdot 1.218} = 0.146 \text{ W}/(\text{m}^2 \cdot \text{K})$$

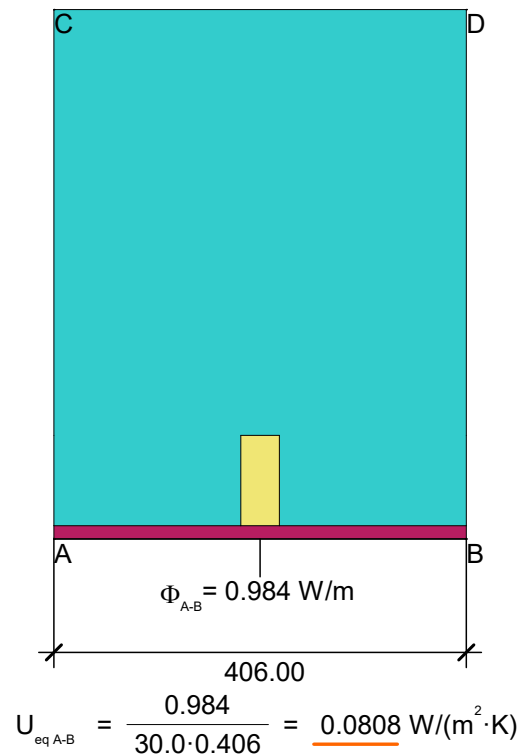

$$U_{\text{eq A-B}} = \frac{0.984}{30.0 \cdot 0.406} = 0.0808 \text{ W}/(\text{m}^2 \cdot \text{K})$$

Panel Junction Psi-value

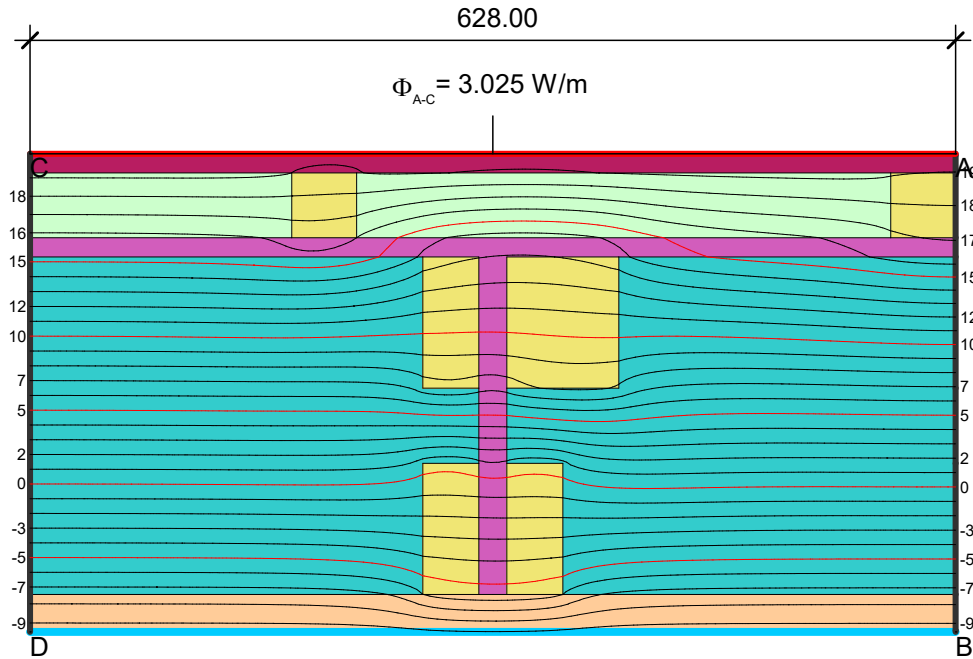

$$\Psi_{A-C,*} = \frac{3.025}{30.0} - 0.146 \cdot 0.628 = 0.009 \text{ W/(m}\cdot\text{K)}$$

Material	$\lambda[\text{W}/(\text{m}\cdot\text{K})]$	ϵ	$\mu[-]$
Blown Cellulose	0.041	0.900	1.000
Fibreglass Batt, generic	0.050	0.900	1.000
Gypsum plasterboard	0.250	0.900	7.000
Plywood 500 kg/m ³	0.130	0.900	135.000
SONOclimat eco4	0.053	0.900	1.000
Softwood 500, typical construction timber	0.130	0.900	

Boundary Condition	$q[\text{W}/\text{m}^2]$	$\theta[^\circ\text{C}]$	$R[(\text{m}^2\cdot\text{K})/\text{W}]$	ϵ	$\phi[\%]$
Exterior, ventilated		-10.000		0.130	
Interior, normal, horizontal		20.000		0.130	
Symmetry/Model section	0.000				

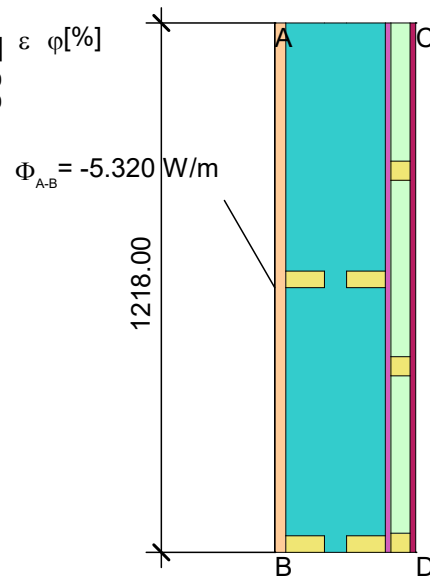

$$U_{\text{eq A-B}} = \frac{5.32}{30.0 \cdot 1.218} = 0.146 \text{ W}/(\text{m}^2\cdot\text{K})$$

Wall to Basement Slab Psi-value

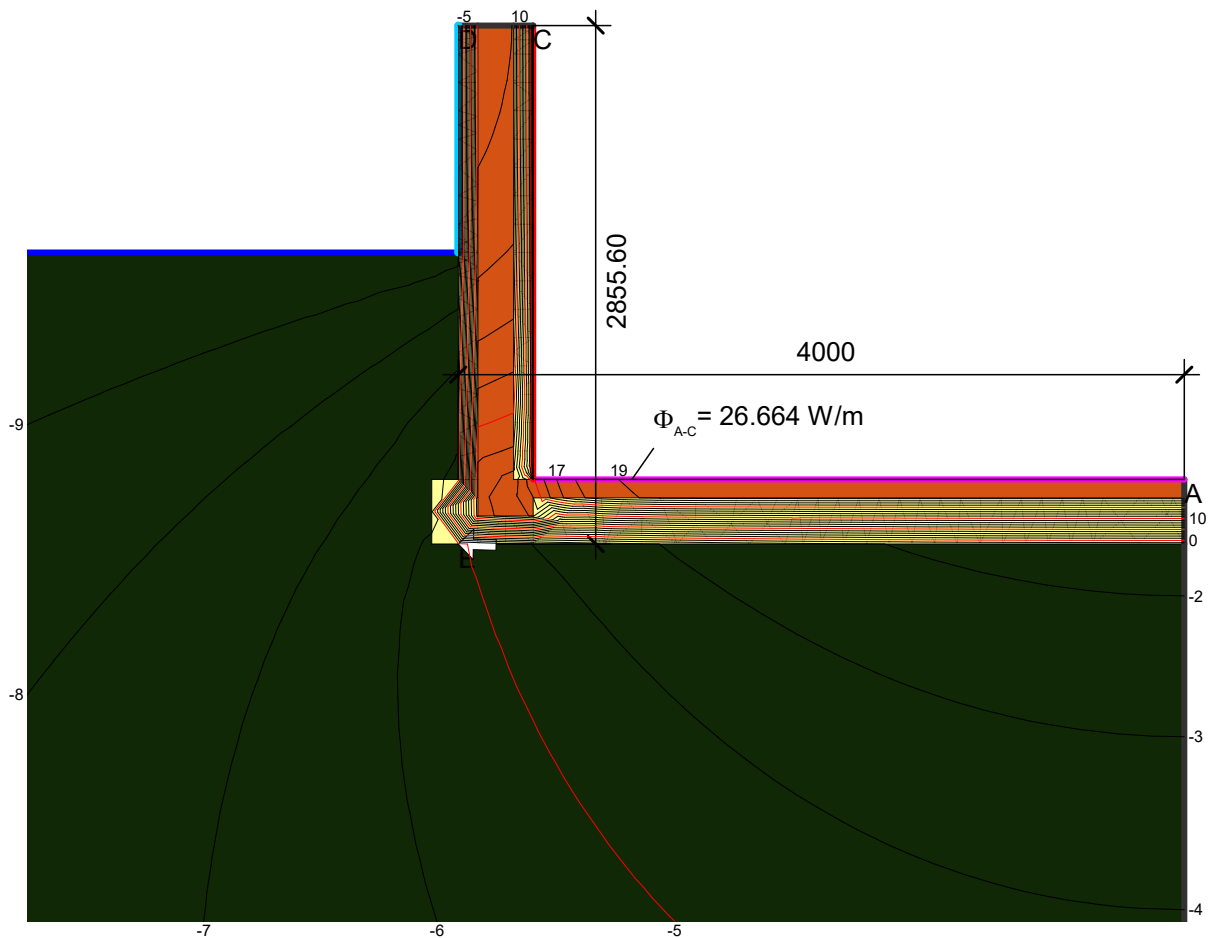

$$\Psi_{A-E-C} = \frac{26.664}{30.0} - \frac{13.491}{30.0} - 0.158 \cdot 2.856 = -0.011 \text{ W/(m}\cdot\text{K)}$$

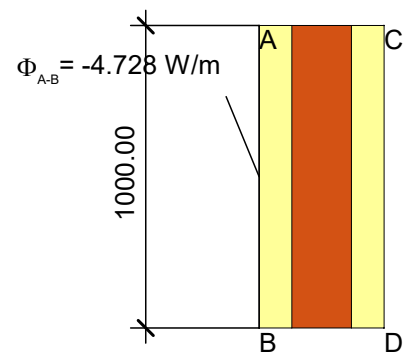

$$U_{eq A-B} = \frac{4.728}{30.0 \cdot 1.0} = 0.158 \text{ W/(m}^2\cdot\text{K)}$$

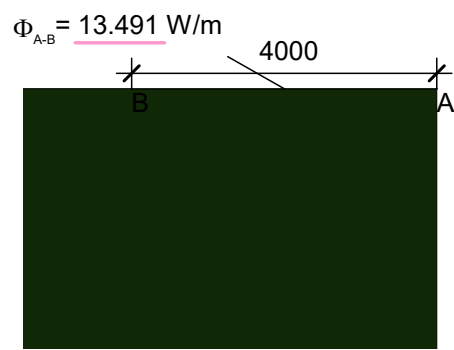

Material	λ [W/(m·K)]	ϵ	μ [-]
Concrete, reinforced (with 1% of steel)	2.300	0.900	105.000
Sand and gravel	2.000	0.900	50.000
Type 3 EPS	0.036	0.900	1.000

Boundary Condition	q [W/m ²]	θ [°C]	R [(m ² ·K)/W]	ϵ	ϕ [%]
Exterior, normal		-10.000		0.040	
Exterior, ventilated		-10.000		0.130	
Interior, heat flux, downwards	20.000			0.170	
Interior, normal, horizontal		20.000		0.130	
Symmetry/Model section	0.000				

Wall to Slab on Grade Psi-value

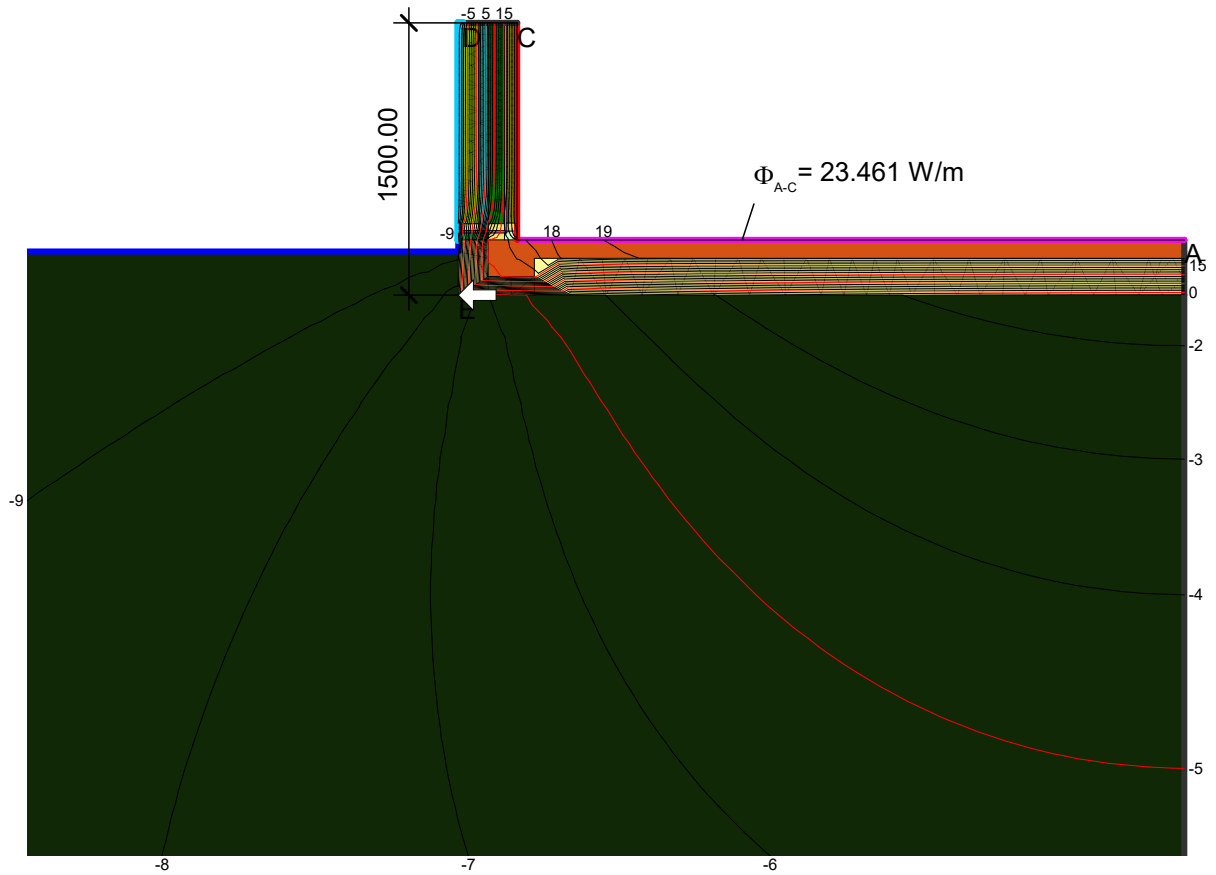

$$\Psi_{A-E-C,*} = \frac{23.461}{30.0} - \frac{16.021}{30.0} - 0.146 \cdot 1.5 = 0.030 \text{ W/(m}\cdot\text{K)}$$

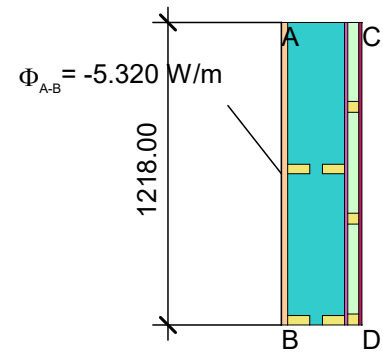

$$U_{\text{eq A-B}} = \frac{5.32}{30.0 \cdot 1.218} = 0.146 \text{ W/(m}^2\cdot\text{K)}$$

$$\Phi_{A-B} = 16.021 \text{ W/m}$$

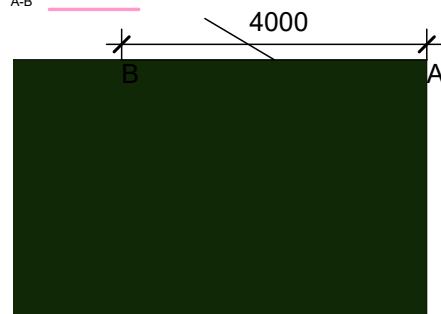

Material	λ [W/(m·K)]	ϵ	μ [-]
BOSS Wall Eq. Cond. 1	0.045	0.900	1.000
BOSS Wall Eq. Cond. 2	0.057	0.900	1.000
BOSS Wall Eq. Cond. 3	0.045	0.900	1.000
Blown Cellulose	0.041	0.900	1.000
Concrete, reinforced (with 1% of steel)	2.300	0.900	105.000
Fibreglass Batt, generic	0.050	0.900	1.000
Gypsum plasterboard	0.250	0.900	7.000
Plywood 500 kg/m3	0.130	0.900	135.000
ROCKWOOL Brandriegelplatte Coverrock BR	0.036	0.900	1.000
SONOclimat eco4	0.053	0.900	1.000
Sand and gravel	2.000	0.900	50.000
Softwood 500, typical construction timber	0.130	0.900	1.000
Type 3 EPS	0.036	0.900	1.000

Boundary Condition	q [W/m ²]	θ [°C]	R [(m ² ·K)/W]	ϵ	ϕ [%]
Exterior, normal		-10.000		0.040	
Exterior, ventilated		-10.000		0.130	
Interior, heat flux, downwards		20.000		0.170	
Interior, normal, horizontal		20.000		0.130	
Symmetry/Model section	0.000				

AGW to BGW Psi-value

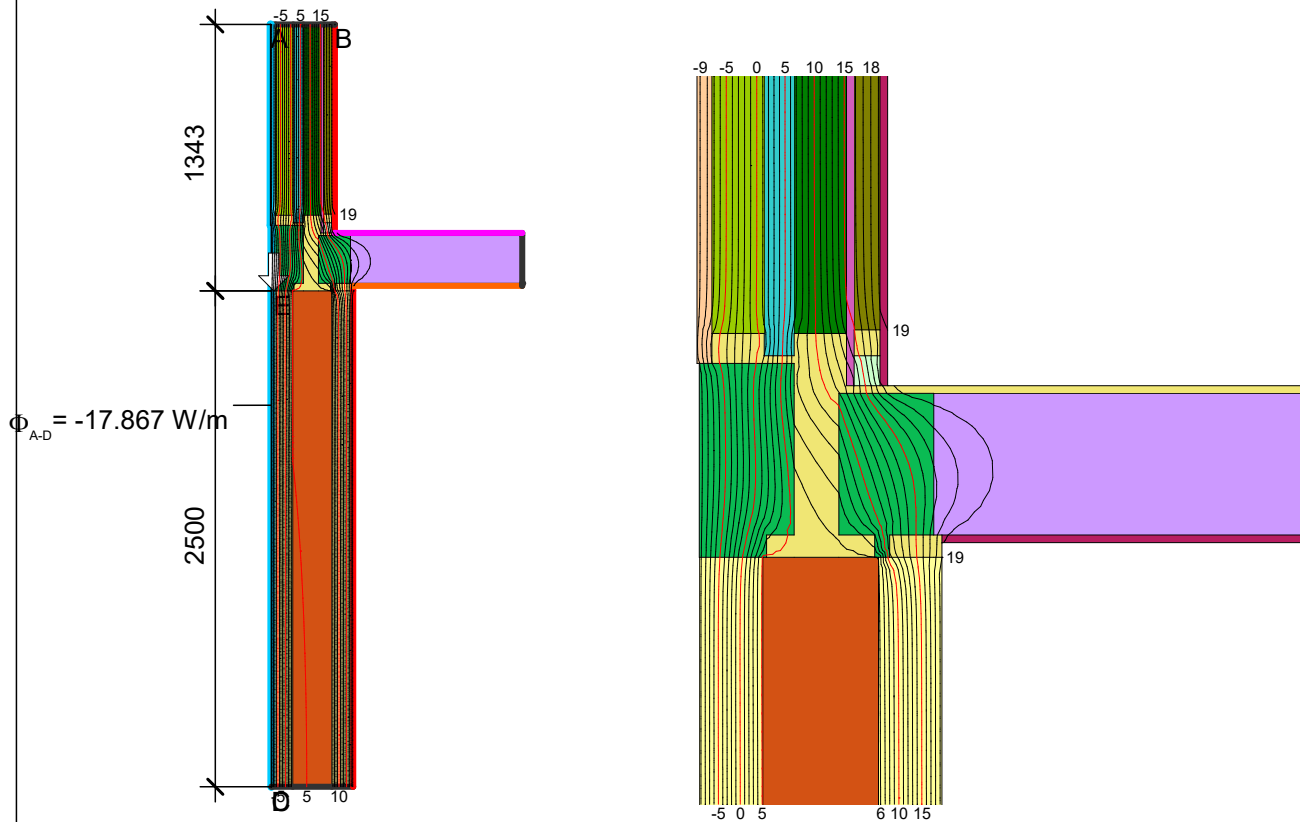

$$\Psi_{A-E-C} = \frac{17.867}{30.0} - 0.146 \cdot 1.343 - 0.158 \cdot 2.5 = 0.006 \text{ W}/(\text{m} \cdot \text{K})$$

Material	λ [W/(m·K)]	ϵ	μ [-]
BOSS Wall Eq. Cond. 1	0.045	0.900	1.000
BOSS Wall Eq. Cond. 2	0.057	0.900	1.000
BOSS Wall Eq. Cond. 3	0.045	0.900	1.000
Blown Cellulose	0.041	0.900	1.000
Blown Cellulose, Low Density	0.054	0.900	1.000
Concrete, reinforced (with 1% of steel)	2.300	0.900	105.000
Fibreglass Batt, generic	0.050	0.900	1.000
Gypsum plasterboard	0.250	0.900	7.000
Plywood 500 kg/m ³	0.130	0.900	135.000
ROCKWOOL Brandriegelplatte Coverrock BR	0.036	0.900	1.000
SONOclimat eco4	0.053	0.900	1.000
Softwood 500, typical construction timber	0.130	0.900	1.000
Type 3 EPS	0.036	0.900	1.000

Boundary Condition	q [W/m ²]	θ [°C]	R [(m ² ·K)/W]	ϵ	ϕ [%]
Exterior, ventilated		-10.000	0.130		
Interior, heat flux, downwards		20.000	0.170		
Interior, heat flux, upwards		20.000	0.100		
Interior, normal, horizontal		20.000	0.130		
Symmetry/Model section	0.000				

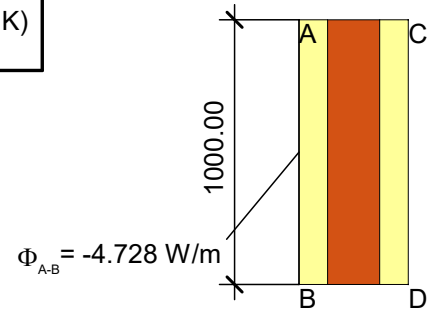

$$U_{eq A-B} = \frac{4.728}{30.0 \cdot 1.0} = 0.158 \text{ W}/(\text{m}^2 \cdot \text{K})$$

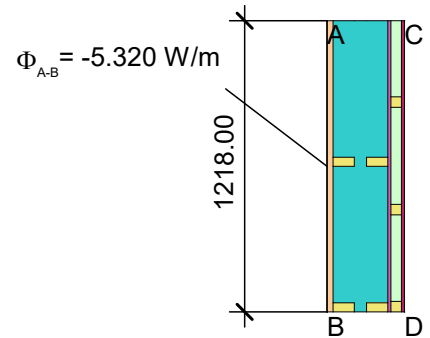

$$U_{eq A-B} = \frac{5.32}{30.0 \cdot 1.218} = 0.146 \text{ W}/(\text{m}^2 \cdot \text{K})$$

Window Head Psi-install

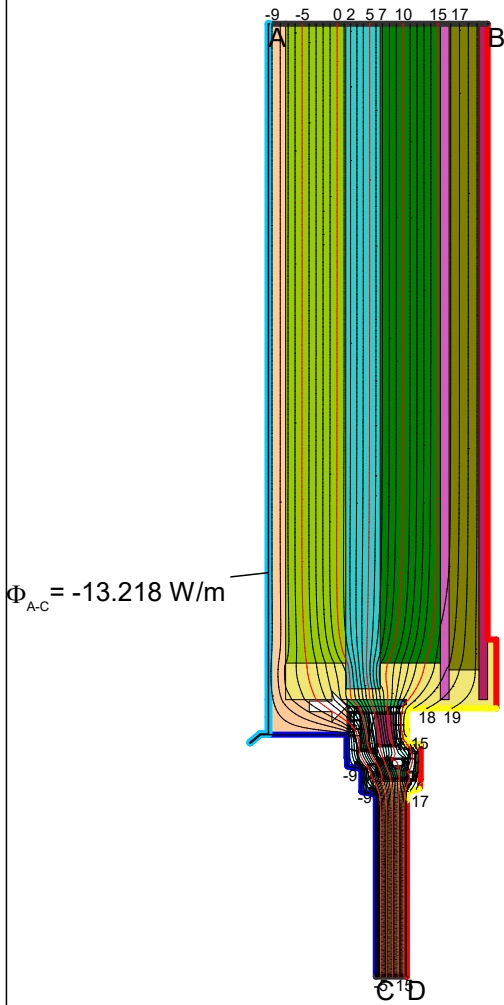

Material	λ [W/(m·K)]	ϵ	μ [-]
Aluminium (Si Alloys)	160.000	0.900	
BOSS Wall Eq. Cond. 1	0.045	0.900	1.000
BOSS Wall Eq. Cond. 2	0.057	0.900	1.000
BOSS Wall Eq. Cond. 3	0.045	0.900	1.000
Bachl EPS F-040	0.040	0.900	60.000
Blown Cellulose	0.041	0.900	1.000
Gypsum plasterboard	0.250	0.900	7.000
PU Foam $k=0.035$	0.035	0.900	1.000
PVC (polyvinylchloride), rigid	0.170	0.900	
PVC, flexible (PVC-P) 40% softener	0.140	0.900	
Panel	0.035	0.900	
Plywood 500 kg/m ³	0.130	0.900	135.000
ROCKWOOL Brandriegelplatte Coverrock BR	0.036	0.900	1.000
SONOclimat eco4	0.053	0.900	1.000
Softwood 500, typical construction timber	0.130	0.900	
Steel	50.000	0.900	
Steel	50.000	0.300	
Ultradur	0.500	0.900	
Urethane Polyurethane (Thermal Break) $k=0.21$	0.210	0.900	1.000
illbruck - Pactan P 4031	0.031	0.900	
Unventilated air cavity *			1.000

* EN ISO 10077-2:2017, 6.4.3/anisotrop

Boundary Condition	q [W/m ²]	θ [°C]	R [(m ² ·K)/W]	ϵ	ϕ [%]
Exterior, normal		-10.000	0.040		
Exterior, ventilated		-10.000	0.130		
Interior, frame, normal		20.000	0.130		
Interior, frame, reduced		20.000	0.200		
Interior, normal, horizontal		20.000	0.130		
Symmetry/Model section	0.000				
Epsilon 0.9				0.900	
ϵ 0.3 (galvanized surface)				0.300	

$$\Psi_{A-E-C,*} = \frac{13.218}{30.0} - \frac{0.146 \cdot 1.01}{30.0} - \frac{8.301}{30.0} = 0.017 \text{ W/(m} \cdot \text{K)}$$

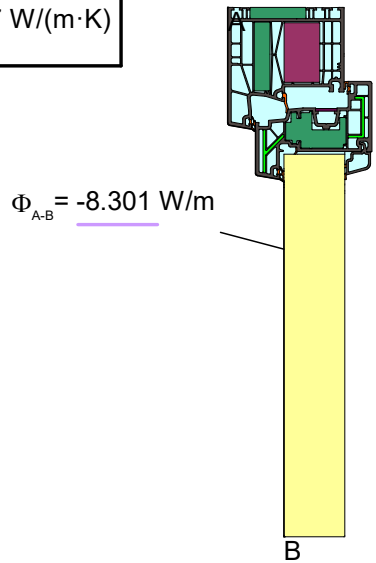
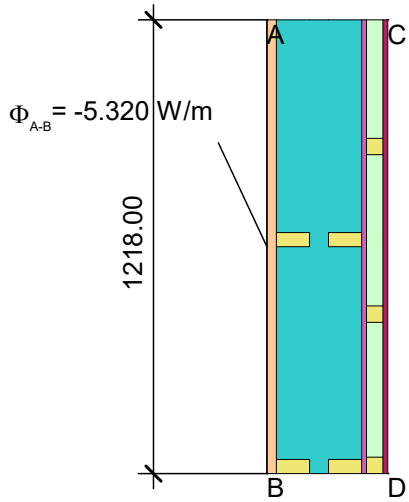

$$U_{eq \text{ A-B}} = \frac{5.32}{30.0 \cdot 1.218} = 0.146 \text{ W/(m}^2 \cdot \text{K)}$$

Window Sill Psi-install

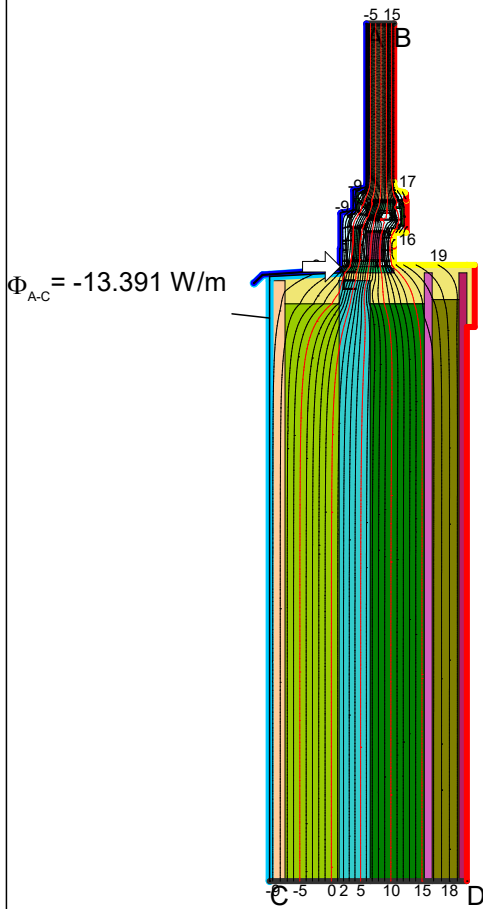

Material	λ [W/(m·K)]	ϵ	μ [-]
Aluminium (Si Alloys)	160.000	0.900	
BOSS Wall Eq. Cond. 1	0.045	0.900	1.000
BOSS Wall Eq. Cond. 2	0.057	0.900	1.000
BOSS Wall Eq. Cond. 3	0.045	0.900	1.000
Bachl EPS F-040	0.040	0.900	60.000
Blown Cellulose	0.041	0.900	1.000
Gypsum plasterboard	0.250	0.900	7.000
PU Foam $\kappa=0.035$	0.035	0.900	1.000
PVC (polyvinylchloride), rigid	0.170	0.300	
PVC (polyvinylchloride), rigid	0.170	0.900	
PVC, flexible (PVC-P) 40% softener	0.140	0.300	
PVC, flexible (PVC-P) 40% softener	0.140	0.900	
Panel	0.035	0.900	
Plywood 500 kg/m3	0.130	0.900	135.000
ROCKWOOL Brandriegelplatte Coverrock BR	0.036	0.900	1.000
SONOclimat eco4	0.053	0.900	1.000
Softwood 500, typical construction timber	0.130	0.900	
Steel	50.000	0.900	
Ultradur	0.500	0.900	
Urethane Polyurethane (Thermal Break) $\kappa=0.21$	0.210	0.900	1.000
ilbruck - Pactan P 4031	0.031	0.900	
Unventilated air cavity *			1.000

* EN ISO 10077-2:2017, 6.4.3/anisotrop

Boundary Condition	q [W/m ²]	θ [°C]	R [(m ² ·K)/W]	ϵ	ϕ [%]
Exterior, normal	-10.000		0.040		
Exterior, ventilated	-10.000		0.130		
Interior, frame, normal	20.000		0.130		
Interior, frame, reduced	20.000		0.200		
Interior, normal, horizontal	20.000		0.130		
Symmetry/Model section	0.000				
Epsilon 0.9				0.900	
ϵ 0.3 (galvanized surface)				0.300	

$$\Psi_{A-E-C,*} = \frac{13.391}{30.0} - \frac{8.301}{30.0} - 0.146 \cdot 1.01 = 0.023 \text{ W}/(\text{m} \cdot \text{K})$$

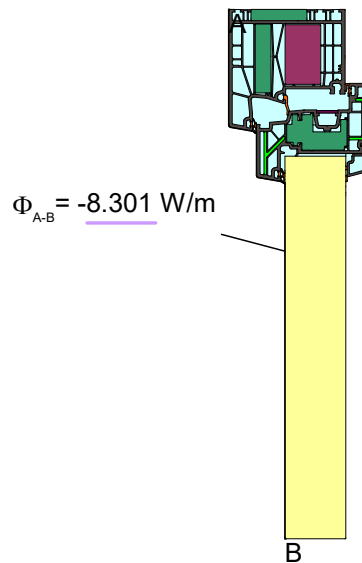
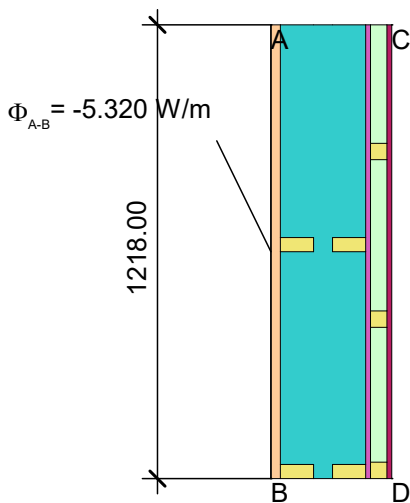

$$U_{\text{eq A-B}} = \frac{5.32}{30.0 \cdot 1.218} = 0.146 \text{ W}/(\text{m}^2 \cdot \text{K})$$

External Corner Psi-value

$\Phi_{-c} = -9.376 \text{ W/m}$

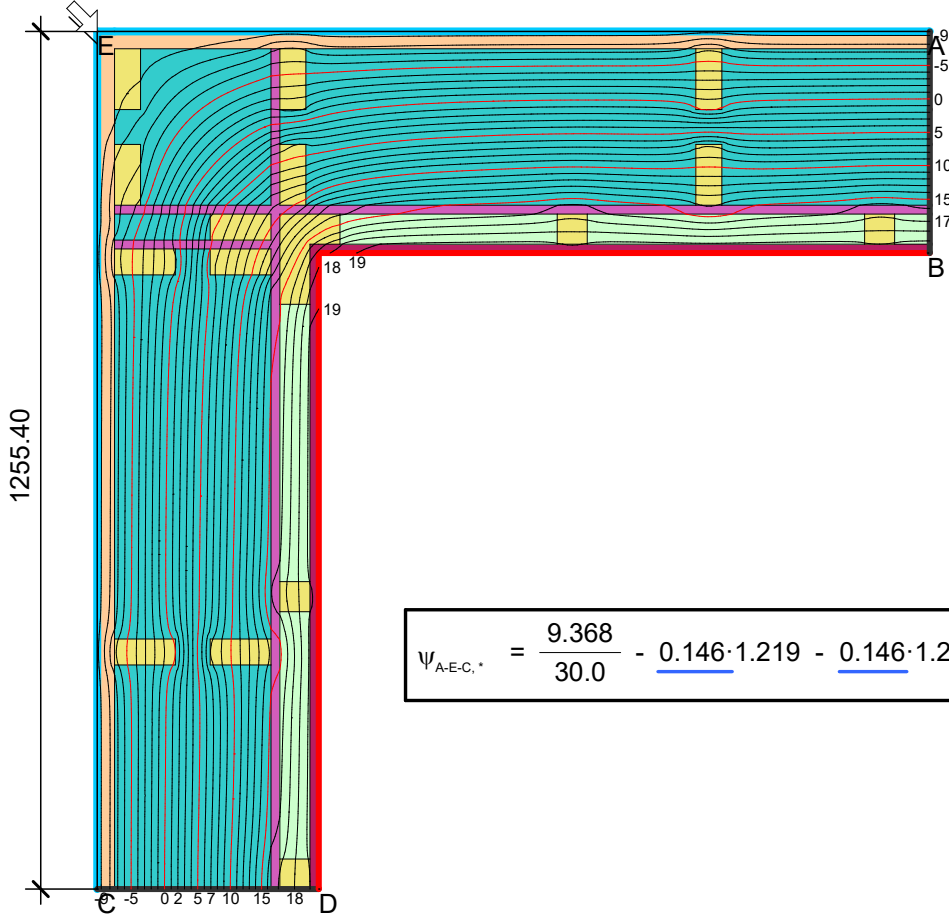

$$\psi_{A-E-C,*} = \frac{9.368}{30.0} - 0.146 \cdot 1.219 - 0.146 \cdot 1.255 = -0.048 \text{ W/(m}\cdot\text{K)}$$

Material	λ [W/(m·K)]	ϵ	μ [-]
Blown Cellulose	0.041	0.900	1.000
Fibreglass Batt, generic	0.050	0.900	1.000
Gypsum plasterboard	0.250	0.900	7.000
Plywood 500 kg/m3	0.130	0.900	135.000
SONOclimat eco4	0.053	0.900	1.000
Softwood 500, typical construction timber	0.130	0.900	

Boundary Condition	q [W/m ²]	θ [°C]	R [(m ² ·K)/W]	ϵ	ϕ [%]
Exterior, ventilated		-10.000		0.130	
Interior, normal, horizontal		20.000		0.130	
Symmetry/Model section	0.000				

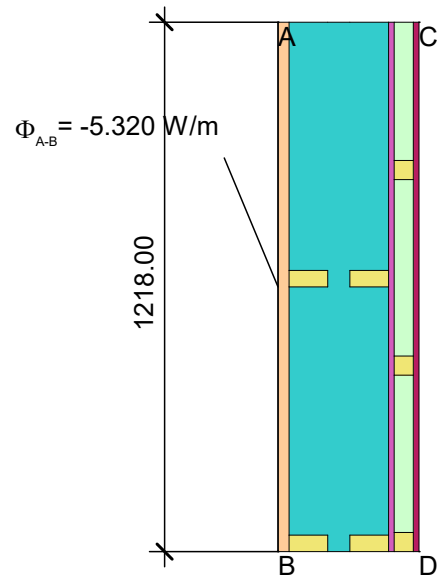

$\Phi_{A-B} = -5.320 \text{ W/m}$

$$U_{eq A-B} = \frac{5.32}{30.0 \cdot 1.218} = 0.146 \text{ W/(m}^2\cdot\text{K)}$$

Internal Corner Psi-value

$\Phi_{A-C} = 7.981 \text{ W/m}$

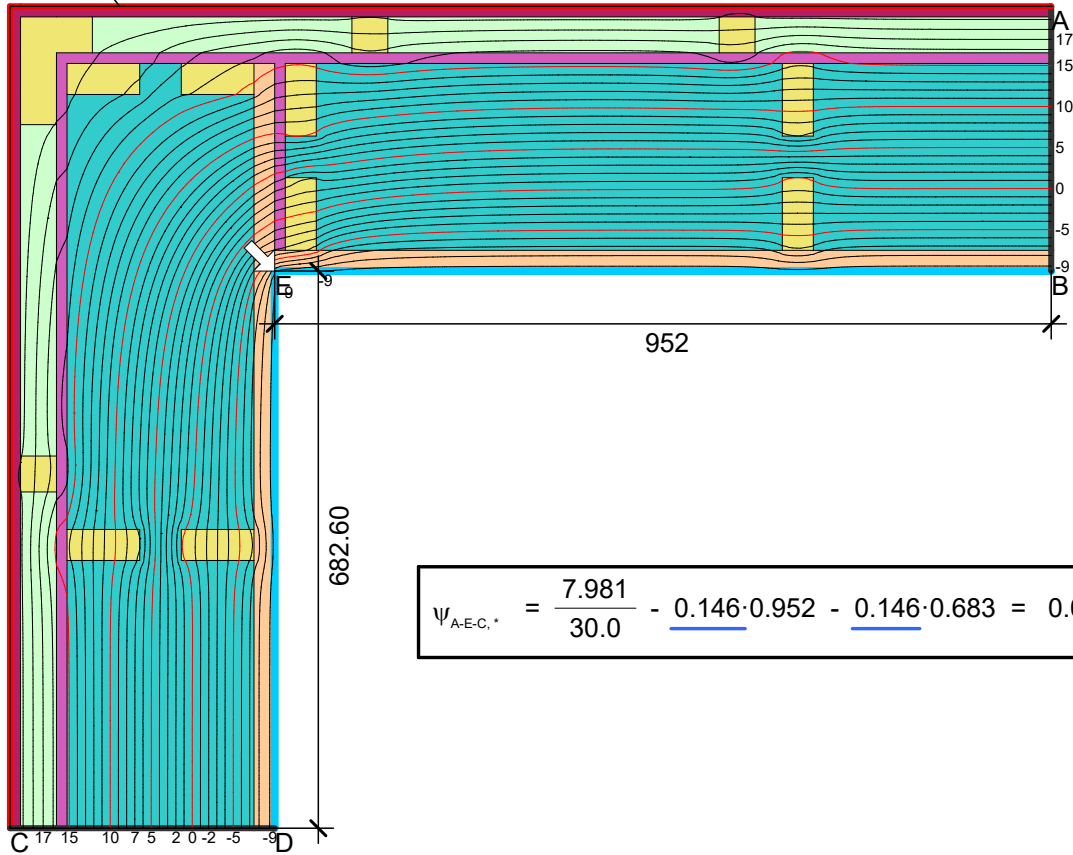

$$\Psi_{A-E-C,*} = \frac{7.981}{30.0} - 0.146 \cdot 0.952 - 0.146 \cdot 0.683 = 0.028 \text{ W/(m}\cdot\text{K)}$$

Material	λ [W/(m·K)]	ϵ	μ [-]
Blown Cellulose	0.041	0.900	1.000
Fibreglass Batt, generic	0.050	0.900	1.000
Gypsum plasterboard	0.250	0.900	7.000
Plywood 500 kg/m ³	0.130	0.900	135.000
SONOclimat eco4	0.053	0.900	1.000
Softwood 500, typical construction timber	0.130	0.900	

Boundary Condition	q [W/m ²]	θ [°C]	R [(m ² ·K)/W]	ϵ	ϕ [%]
Exterior, ventilated		-10.000		0.130	
Interior, normal, horizontal		20.000		0.130	
Symmetry/Model section	0.000				

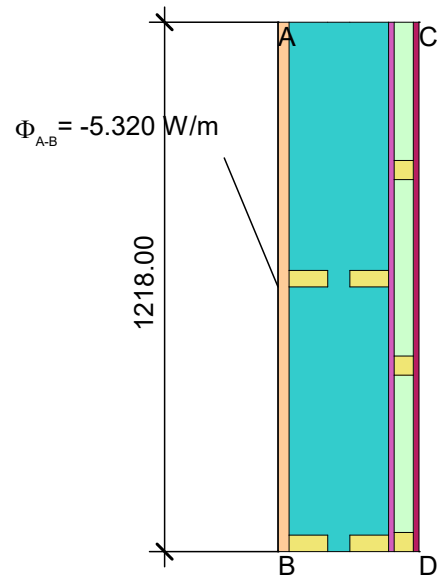

$$U_{eq A-B} = \frac{5.32}{30.0 \cdot 1.218} = 0.146 \text{ W/(m}^2\cdot\text{K)}$$